

Instructions for Lynx LX2 3.5-10x50 fitted with SA Hunters reticle

Knowing exactly where to aim at a distant target and get accurate bullet placement is of utmost importance to the hunter and sport shooter alike. The further the target, the more difficult this task becomes. The SA Hunters reticle has been designed specifically for South African hunters and sport shooters to help them achieve this goal. It is practical, easy to use and provides plenty of functionality, with aiming points that compensate for distance as well as cross-winds. It is calibrated in metres for distance and km/h for winds and is designed to work with most popular manufactured ammunition.

To compensate for bullet drop over distance the SA Hunters reticle has four hold-over aiming points—two range bars plus three small marker points—on the vertical line below the centre cross. Although the reticle is designed to work with most manufactured standard and high velocity ammunition with the scope set at 9x the scope magnification may be tweaked for ammunition that is not specifically catered for.

HOW TO USE THE SA HUNTERS RETICLE

First determine whether you are using standard velocity ammunition (between 2500 ft/s and 2999 ft/s) or high velocity ammunition (between 3000 ft/s and 3400 ft/s).

100M ZERO AND USE OF THE RETICLE USING STANDARD VELOCITY AMMUNITION (FROM 2 500 FT/S TO 2 999 FT/S)

Examples of standard velocity ammunition:

PMP manufactured ammunition for 243 Win (100gr), .25-06 Rem., 270 Win. 7x64 Bren, 7mm Rem. Mag. (170gr), 308 Win, 30-06 Spr., 300 Win. Mag. and 303 Brti. (150gr).

For ammunition such as these, and similar combinations, set the scope to 9x and zero at 100 metres on the main cross hair. Aiming points for both wind and distance are shown on the image on the right. For example, if the target is at 300 metres and a 20km/h wind is blowing from the right to the left, the left tip of the second (longer) range bar will be the aiming point.

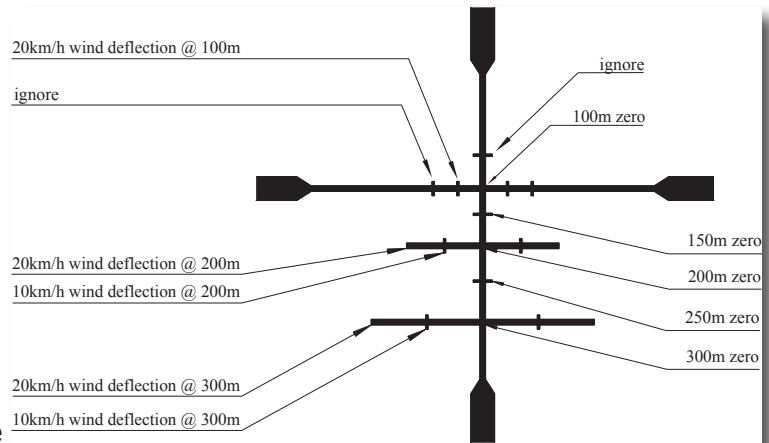

100M ZERO AND USE OF THE RETICLE USING HIGH VELOCITY AMMUNITION (FROM 3 000 FT/S TO 3 400 FT/S)

Examples of high velocity ammunition:

PMP manufactured ammunition for 222 Rem., 223 Rem., 243 Win (180gr), 7mm Rem. Mag. (150gr) and most ammunition loaded with Impala LWHV bullets.

For ammunition such as these, and similar combinations, set the scope to 9x and zero at 100 metres on the small cross hair. Aiming points for both wind and distance are shown on the image on the right. For example, if the target is at 300 metres and a 10km/h wind is blowing from the right to the left, the first (short) range bar will be used and the aiming point is the small marker in the middle of the left section of that bar, shown on the diagram on the right as 10km/h wind deflection.

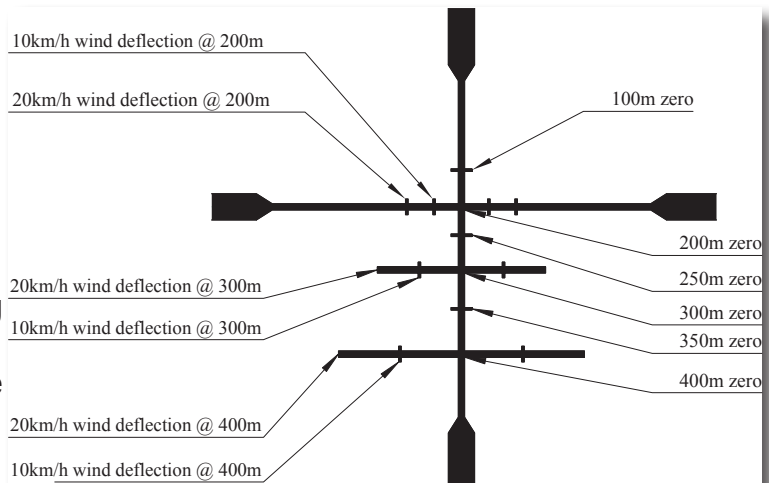

ADVANCED USE AND ZEROING THE SCOPE

The instructions on the previous page are suitable for general hunting use. The accuracy of the hold-over range bars can be increased for standard velocity ammunition by zeroing the rifle at 300 metres on the bottom range bar with the scope at 9x and for high velocity ammunition by zeroing the scope at 300 metres on the middle (first) range bar with the scope set at 9x.

Shooters who wish to maximally optimize the reticle for a specific rifle and load can do so in the following way:

OPTIMIZE THE SA HUNTERS RETICLE FOR USE WITH STANDARD VELOCITY AMMUNITION (2 500FT/s TO 2 999FT/s)

1. Zero the rifle using the main cross hair at 100m.
2. Use a long vertical target to allow for bullet drop and place it at 300 metres with an aiming point close to the top of the target.
3. Shoot a group at the 300m target using the main cross hair. The bullet group will be about 420mm below the aiming point.
4. Stick a bright patch, that will be visible from 300 metres away, in the middle of the bullet group.
5. Place the rifle on a steady rest and aim again at the 300m target with the main cross hair.
6. Keeping the rifle with the main cross hair on the target adjust the magnification until the second range bar is on top of the bright patch.
7. Note the magnification that the scope is set to at this point. This magnification setting should be used in future for the same specific load to obtain high accuracy in hold-over aiming.

OPTIMIZE THE SA HUNTERS RETICLE FOR HIGH VELOCITY AMMUNITION (3 000FT/s TO 3 400FT/s)

1. Zero the rifle using the main cross hair at 200m.
2. Use a long vertical target to allow for bullet drop and place it at 300m with an aiming point close to the top of the target.
3. Shoot a group at the 300m target using the main cross hair. The bullet group will be about 180mm below the aiming point.
4. Stick a bright patch, that will be visible from 300 metres away, in the middle of the bullet group.
5. Place the rifle on a steady rest and aim again at the 300m target with the main cross hair.
6. Keeping the rifle with the main cross hair on the target and adjust the magnification until the first range bar is on top of the bright patch.
7. Note the magnification that the scope is set to at this point. This magnification setting should be used in future for the same specific load to obtain high accuracy in hold-over aiming.

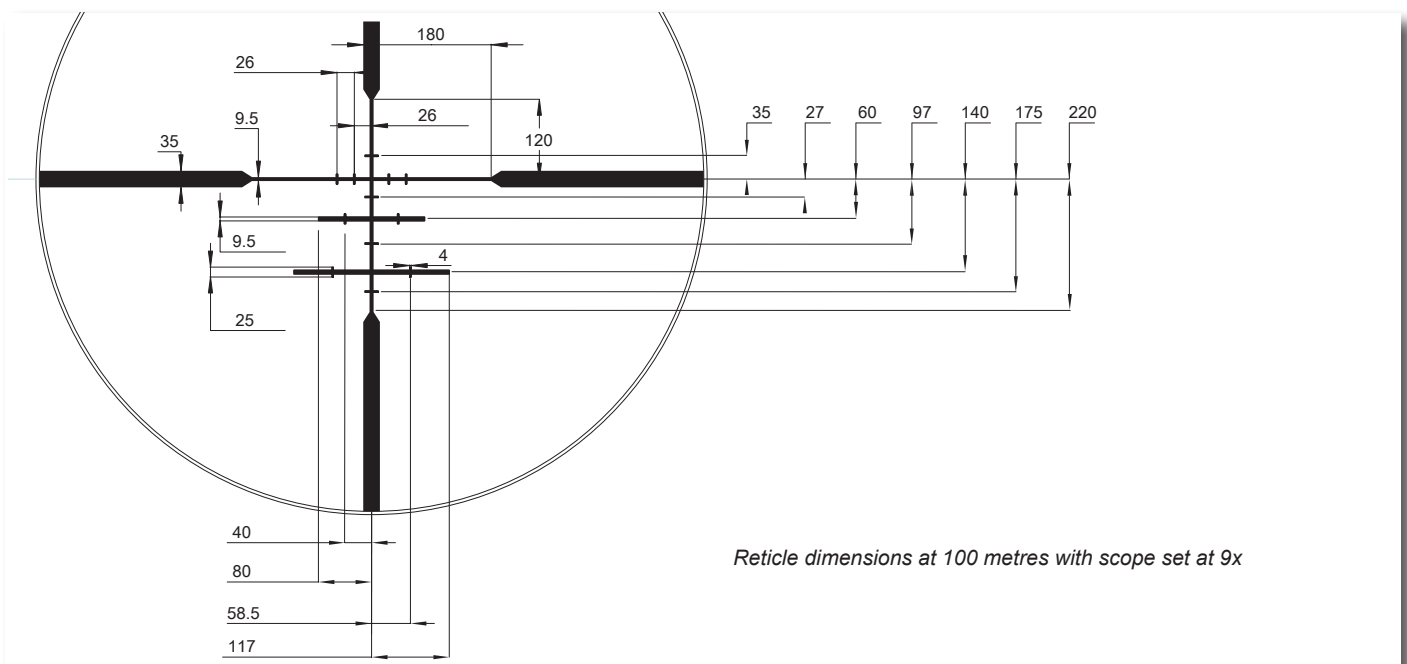

Reticle dimensions at 100 metres with scope set at 9x

SA Hunters reticle was designed by Hercules Louw, design drawings are courtesy Daniël Louw.

Lynx Optics (Pty) Limited

PO Box 98078 Sloane Park South Africa 2152 • tel +27(0)11 792 6644 • fax +27(0)11 792 8923 • info@lynx.co.za • www.lynx.co.za